

BALMORAL SUBSEA TEST CENTRE

Test vessel TC1

Safe working pressure	475 bar
Orientation	Vertical
Max internal diameter	2,500mm
Max internal length	8,885mm
Test medium	Fresh water
Working temperature	Ambient (ice can be added for reduced temperature testing)
Penetrator quantity	8
Penetrator ID	50mm
Max pressurisation rate	10 bar/minute approx

TC1 is fitted with a base structure to provide a flat platform and can also be fitted with a sectional frame that can provide a platform at various heights so that items do not have to be lowered to the bottom of the vessel. This can be set at approximately 1.75m intervals and custom heights can be considered.

Handling is carried out by 40t, 20t and 5t overhead cranes. Forklifts up to 9t are available on-site. The test centre has a wide range of standard slings, shackles, etc.

Penetrator ports are fitted with 4" quick action clamp connectors c/w blind hubs. These can be adapted in size to increase the available surface area for mounting bulkhead connectors, hydraulic ports, etc. The main limiting factor is normally the internal diameter of the relevant seal ring. Balmoral can supply blank hubs to be machined to requirements. Custom penetrators can be considered.

Pressure is provided by hydraulic intensifier pumps via a touch screen control panel situated next to the vessel. Test parameters are pre-programmed and a constant ramp up, hold at pressure and ramp down can be carried out automatically. Pressure and temperature readings are fed back to a networked server. A pressure relief valve is fitted to protect the vessel.

Standard 110 and 220 volt electrical supplies are close by along with 16, 32 and 64 amp 3 phase. Workshop air is also available.

A pan and tilt subsea camera is available for use inside the vessel.



BALMORAL SUBSEA TEST CENTRE

Test vessel TC1

Dimensions

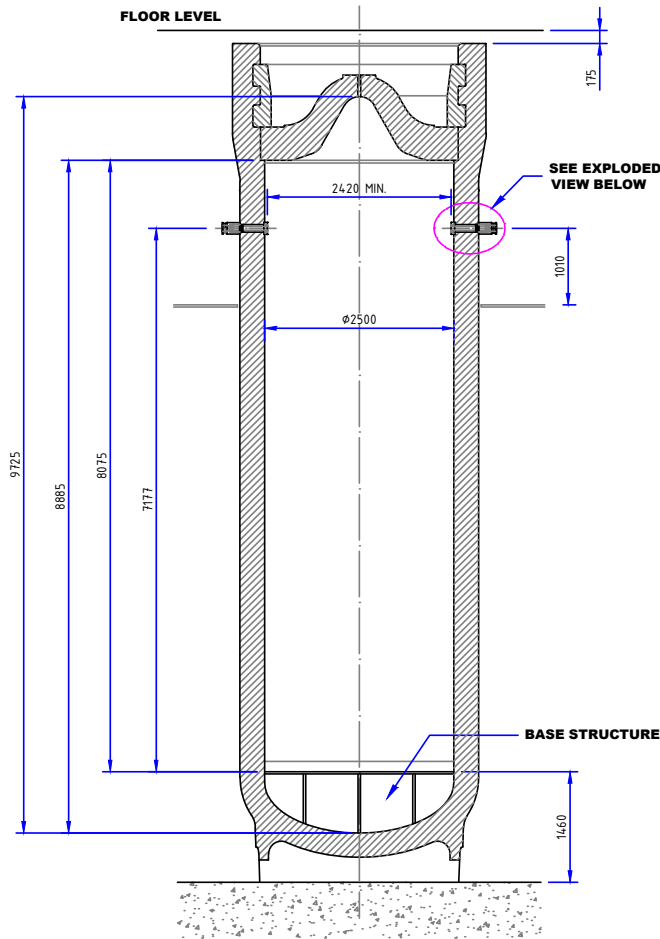

CROSS SECTION

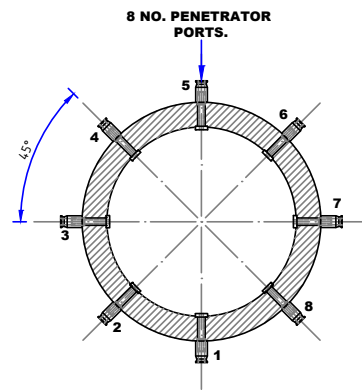

SECTIONAL PLAN VIEW

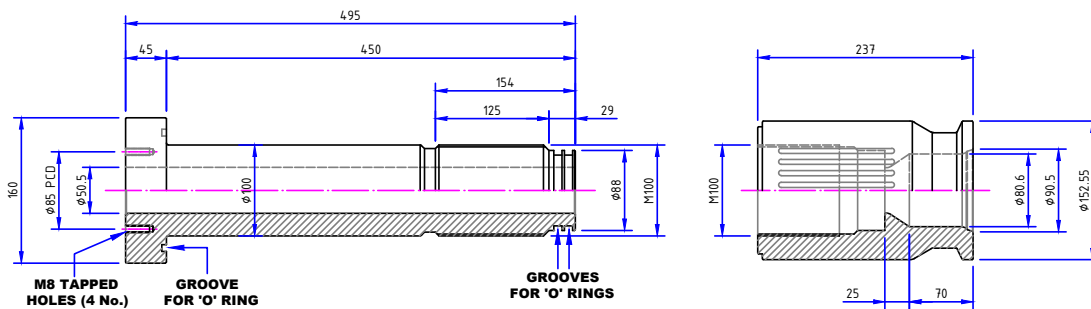

PENETRATOR PIN ASSEMBLY

BALMORAL SUBSEA TEST CENTRE

Test vessel TC1

Modular base frame

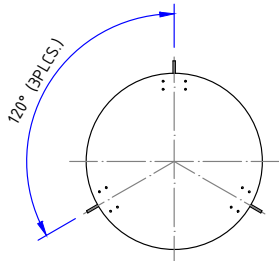

TOP PLAN VIEW

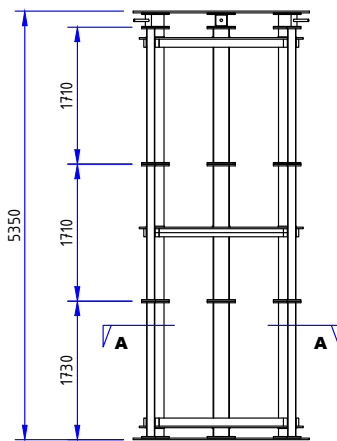

CONFIG. '1'

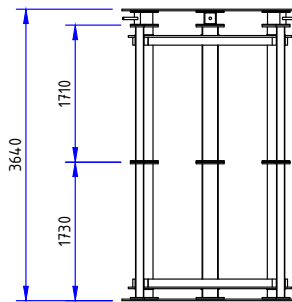

CONFIG. '2'

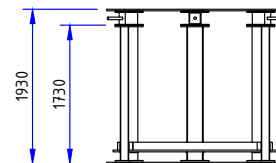

CONFIG. '3'

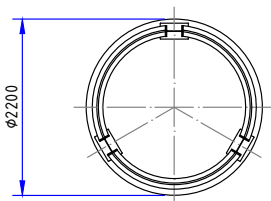

SECTIONAL PLAN A-A

BALMORAL SUBSEA TEST CENTRE

Test vessel TC1

Hub assembly - 4in 31

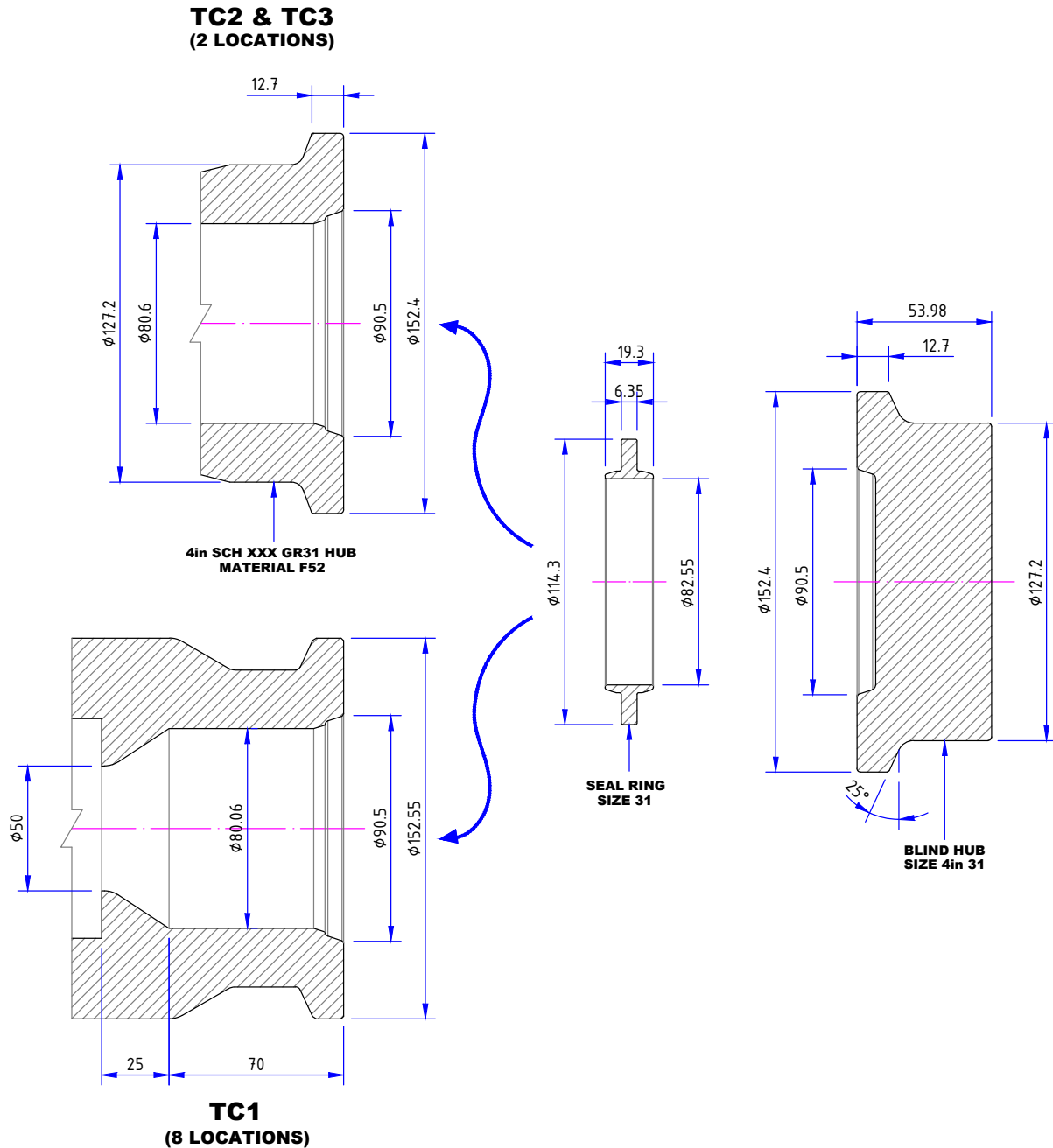

BALMORAL SUBSEA TEST CENTRE

Test vessel TC1

Hub assembly - 6in 52

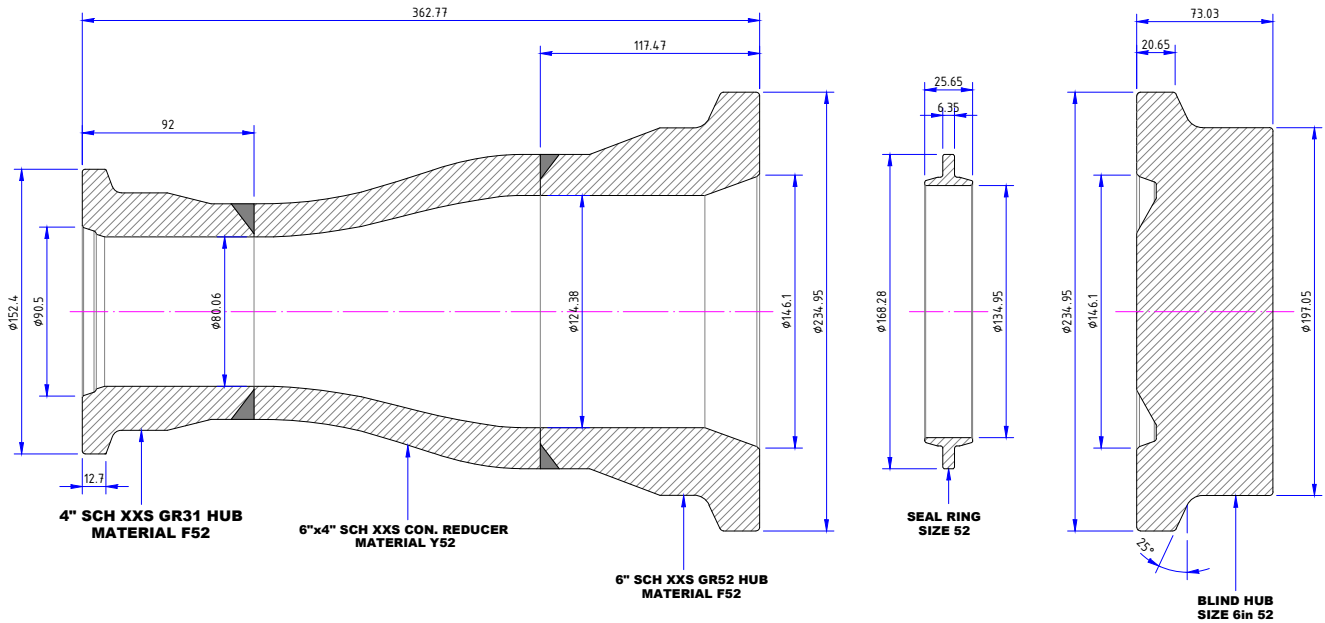

BALMORAL SUBSEA TEST CENTRE

Test vessel TC1

Test basket

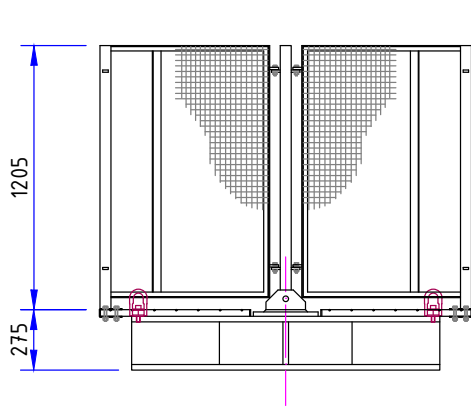

CROSS SECTION

WIRE MESH
REMOVABLE
FENCE

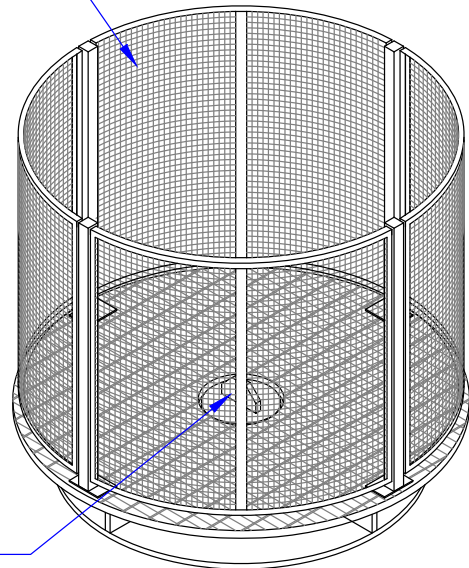

ISOMETRIC VIEW

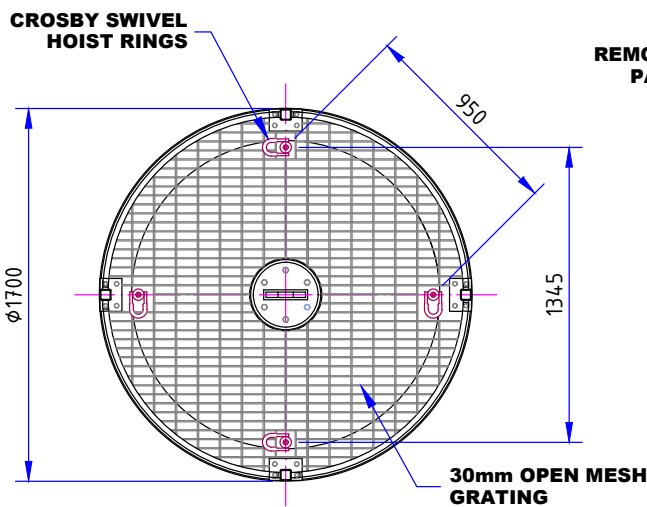

PLAN VIEW

BALMORAL SUBSEA TEST CENTRE

Test vessel TC1

Cutaway section through test centre

